

THIS NEWSLETTER IS A PUBLICATION OF THE FLORIDA ASSOCIATION OF GOVERNMENTAL FLEET ADMINISTRATORS (FAGFA) AND IT IS PUBLISHED TO KEEP FAGFA MEMBERS INFORMED ABOUT THE ASSOCIATION'S ACTIVITIES AND OTHER MATTERS OF INTEREST TO FLEET MANAGERS. THE FAGFA HOPES TO PUBLISH THIS NEWSLETTER, AS A MINIMUM, ON A BIENNIAL BASIS, BUT, MAY FROM TIME TO TIME DO SO MORE OR LESS FREQUENTLY.

FAGFA OFFICERS

PRESIDENT	DAN BUREK	(813) 951-5506	SARASOTA
1st VICE PRESIDENT	VERN TUCKER	(904) 351-6754	OCALA
2nd VICE PRESIDENT	LUIS TAMAYO	(305) 659-8035	WEST PALM BEACH
SECRETARY/TREASURER	ROSE ANN HUNTER	(904) 323-2500x135	SANFORD
EDITOR/ILLUSTRATOR	VERN TUCKER		
TYPIST	NANCY MEAGHER		

SHOULD ANY REPRODUCTION OF THIS PUBLICATION BE DESIRED FOR USE BY ANY INDIVIDUAL OR AGENCY OTHER THAN THE FAGFA OR IT'S MEMBERS, THE EDITOR MUST BE CONTACTED FOR PERMISSION TO DO SO.

TABLE OF CONTENTS

<u>ITEM</u>	<u>PAGE(S)</u>
From the President	1
Profile of New Officers	2
Minutes of the October 1987 General Membership Meeting	4
Attendance for the October 1987 General Membership Meeting	9
For Your Information	10
Proposed Agenda for the April 1988 General Membership Meeting	13
FAGFA Active Membership Roster	15
FAGFA Application for Membership	19

No one can make you feel more humble than the repairman who discovers you've been trying to fix it yourself.

FROM THE PRESIDENT

Greetings and a Happy New Year to you all!

The onset of the new year brings interesting and difficult challenges for all of us in the business of Fleet Management. New technologies, New concepts, New products etc., inundate our senses and mail boxes daily. What works? What doesn't? Will it work for me and my operation? Who can I discuss my problems and successes with?

Look no further! This is the place!

Our members have always risen to the challenge and aptly shared their experiences with each other. Bring along your problems and "Select employees" to our next meeting. Share and solve thru mutual discussion and learning. It's what this association is all about. It's the only method we have to gather requested information for future presentations and provide interesting and informative meetings.

Feel free to call and discuss any subject of interest with association officers. Use this association for your benefit, we're happy to oblige.

Sincerely,

Dan Burek
President

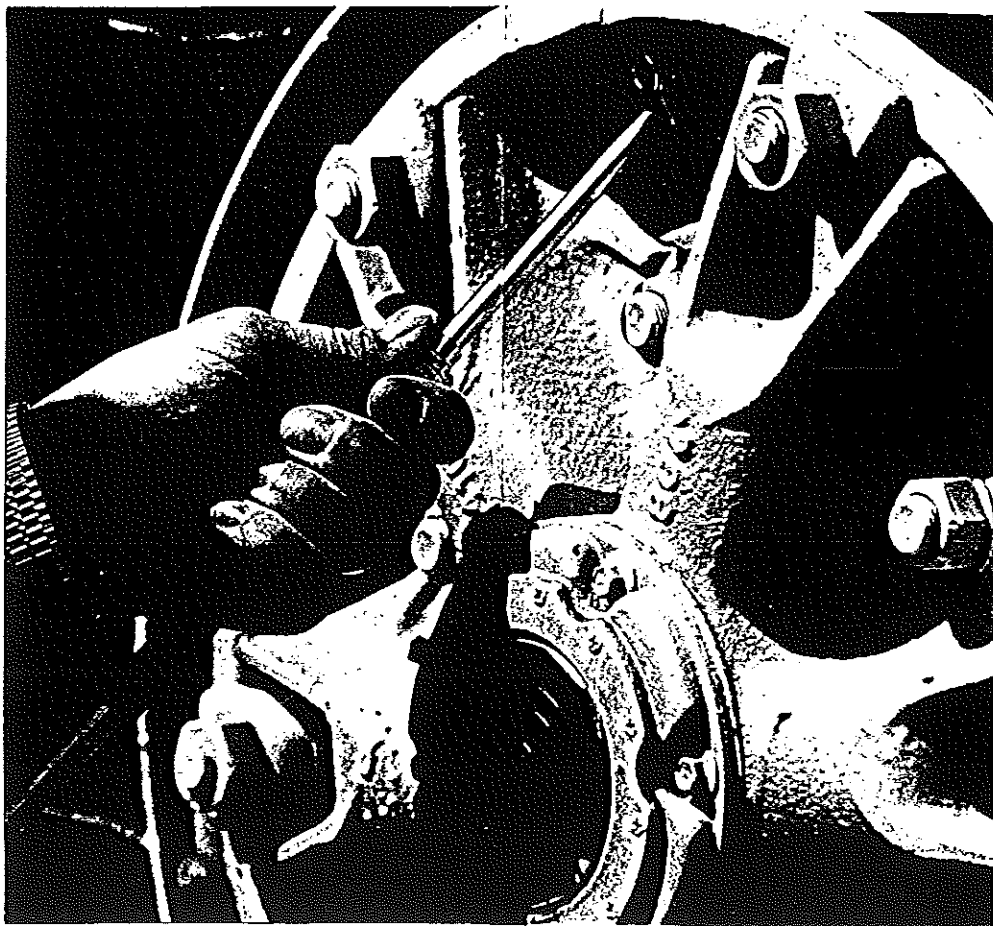

PROFILE OF NEW OFFICERSPresident Dan Burek

Employment History (20 Years) -

- Held various management and operating positions with major carriers such as: Pacific Intermountain Express, Consolidated Freightways, and Supervisor of Transportation for General Electric Company.
- C.O.E. and consultant for Commercial Traffic Services, Inc. with clients such as: American Sterilizer Corp., Lorenz International, Eruite Corp., West Baking Co. serving 480 McDonalds Restaurants, Zurn Industries, etc.
- Fleet Operations Supervisor, City of Tampa, FL.
- Currently - Director, Fleet Management Division, Sarasota County, FL. Past two years.

Education -

BA in Business from Gannon College, Erie, Pennsylvania.

1st Vice President Vern Tucker

Professional Background -

- Division Chief - Aircraft Maintenance Management, U.S. Air Force (Retired 1983).
- Plant Manager - Synergetics, Inc., fabricator of mobile medical diagnostic laboratories, Gainesville, Florida
- Automobile Sales - Northgate Porsche + Audi, BMW, Volkswagen, Gainesville, Florida.
- Currently - Director of Fleet Management for the City of Ocala, Florida.

Education

Associate in Science - Automotive Technology from Los Angeles Metropolitan Colleges, Los Angeles, California.

Professional Affiliations -

American Public Works Association (APWA)
 APWA Institute for Equipment Services
 Florida Association of Governmental Fleet Administrators
 Society of Certified Public Managers

2nd Vice President Luis Tamayo

Education -

1979 Western Michigan University, B.S. in Automotive Management.

Work Background -

- 1980 Allen Test Products, Export Field Training Technician. Duties included travelling overseas to train and repair auto-diagnostic equipment.
- 1982 Instructor, Western Michigan University and Kalamazoo Valley Community College. Taught courses in automatic transmissions and engine electrical systems.
- 1984 City of West Palm Beach, Director of Fleet Maintenance.

Other -

ASE Certified, Member of S.A.E.

Secretary/Treasurer RoseAnn Hunter

Graduated - Jacksonville University, BSc Accounting

Employment History -

- Various positions in the private sector and County government in the finance and accounting areas.
- Currently Fleet Management Director for Seminole County since 1985.

Professional Affiliations -

Member American Public Works Association (APWA)
 Member Florida Association of Governmental Fleet Administrators
 Member National Association of Fleet Administrators (NAFA)

"Whenever you are to do a thing, though it can never be known but to yourself, ask yourself how you would act were all the world looking at you, and act accordingly."

THOMAS JEFFERSON

OFFICIAL MINUTES

GENERAL MEMBERSHIP MEETING

FLORIDA ASSOCIATION OF GOVERNMENTAL FLEET ADMINISTRATORS

October 15-16, 1987
Hilton Inn Florida Center
Orlando, Florida

The October General Membership Meeting was called to order at 8:47 a.m. on October 15 by the Association President, Milton Reid.

The first presentation was made by Mr. John C. Osborn, Executive Director of the Florida Center for Industrial Excellence (CIE). According to Mr. Osborn, the purpose of CIE is to provide in-service training to automotive and general industry workers. Construction of a 140,000 square foot training facility is planned.

The rap session began at 9:05 a.m. with the following items being presented:

- Fred Chester, City of Temple Terrace - General questions.
- Bill Harris, Volusia County - Questioned membership about problems with Ford Crown Victoria sedans with 5.0L fuel injected engines.
- Angel Ramos, City of Gainesville - Discussed failure of heater cores and air conditioner evaporators on Ford automobiles equipped with 5.0L engines.
- Gary Giragosian, City of Boca Raton - Discussed air conditioner drainage systems on Ford vehicles.
- Angel Ramos, City of Gainesville - Discussed Ford brake problems, particularly spongy brake pedal noticed after turning brake drums and discs.
- Buddy Reneau, City of Apopka - Asked questions about specification writing for large or specialized equipment.
- Angel Ramos, City of Gainesville - Queried membership as to the use of total cost bidding.
- Kurt Miller, Pinellas County - Discussed the use of a minimum suggested specification to permit vendors to bid, and to later evaluate the equipment as to its suitability for the intended application.
- Kurt Miller, Pinellas County - Discussed the purchase of used equipment by Pinellas County.
- Marvin Van Wormer, Seminole County - Queried membership as to standardization efforts.

A discussion ensued as to when the dues increase would occur. Some members proposed that the increase take place after the meeting, to allow renewals at the old rate; Bill Harris, Volusia County, clarified his motion to indicate that the rate increase would take place immediately.

Milton Reid opened the floor to nominations for election of Association officers for 1987--1988. Mr. Reid thanked the existing officers and the membership for their support in the past, and indicated that he would be unable to accept a nomination for another term in office. John Neal, Secretary/Treasurer, had already served the two term maximum allowed officers under existing by-laws, and was ineligible for nomination.

For president, Kurt Miller, Pinellas County nominated Dan Burek, Sarasota County, and Vern Tucker, City of Ocala, seconded the motion. George Bay, City of Jacksonville moved to close nominations, Jay Dennett, Pinellas County Sheriff's Office seconded the motion, and the motion carried, effectively electing Dan Burek as the Association president.

For first vice-president, Luis Tamayo, City of West Palm Beach nominated Vern Tucker, City of Ocala, a move that was seconded by Jon Crull, City of Ormond Beach. George Bay, City of Jacksonville moved to close nominations, an unknown individual seconded the motion, and the motion carried, effectively electing Vern Tucker as the Association first vice-president.

For second vice-president, Dan Burek, Sarasota County, nominated Luis Tamayo, City of West Palm Beach, and John Neal, Pinellas County, seconded the motion. George Bay, City of Jacksonville moved to close nominations, Jay Dennett, Pinellas County Sheriff's Office seconded the motion, and the motion carried, effectively electing Luis Tamayo as the Association second vice-president.

For secretary/treasurer, William Massey, City of Gainesville, nominated RoseAnn Hunter, Seminole County, a move that was seconded by Gary Giragosian, City of Boca Raton. Bill Harris, Volusia County moved to close nominations, George Bay, City of Jacksonville, seconded the motion, and the motion carried, effectively electing RoseAnn Hunter as the Association secretary/treasurer.

Elliott Covo, City of Miramar, asked if any regional meetings had been held since the April general membership meeting; no regional meetings had been held. Gary Giragosian, City of Boca Raton, proposed appointing a person to take charge of regional meetings.

Kurt Miller, Pinellas County, commented on the outgoing administration, stating that he could not recall any greater amount of professionalism being displayed by Association officers, and indicated that the effort should continue.

Jon Crull, City of Ormond Beach, moved to adjourn the meeting for the day; Angel Ramos, City of Gainesville, seconded the motion, and the motion carried.

The October general membership meeting reconvened on October 16, and was called to order by Milton Reid at 8:42 a.m. The floor was opened for a rap session, and the following items were presented:

Bob Minton, City of Tampa - Presented general questions to the membership.

Kurt Miller, Pinellas County - Commented on the planned Association tape and film library, offering to get involved with other members in this area. He indicated that his interest was in safety and training videotapes. Milton Reid, instructed Vern Tucker to address this topic in the next issue of Fleetline.

Angel Ramos, City of Gainesville - Mentioned Caterpillar's tape and film library.

Bob Minton, City of Tampa - Discussed a damage and accident report generated by the City of Tampa.

Bob Eichorst, City of Ormond Beach - Queried membership as to Mechanic I starting salaries.

At 9:00 a.m., the rap session was ended; Dan Burek, Sarasota County, introduced Mr. Jack Mears, Executive Director of the Equipment Maintenance Council. Mr. Mears made a slide presentation on equipment maintenance, and discussed the purpose of the Equipment Maintenance Council.

At 10:15 a.m., a presentation on heavy equipment and truck engines was made by representatives from DEERE AND COMPANY AND COASTAL POWER.

Following that presentation, a brief discussion ensued as to room reservation practices for the general meeting to be held on April 21 and 22, 1988.

The October general membership meeting adjourned at 11:47 a.m.

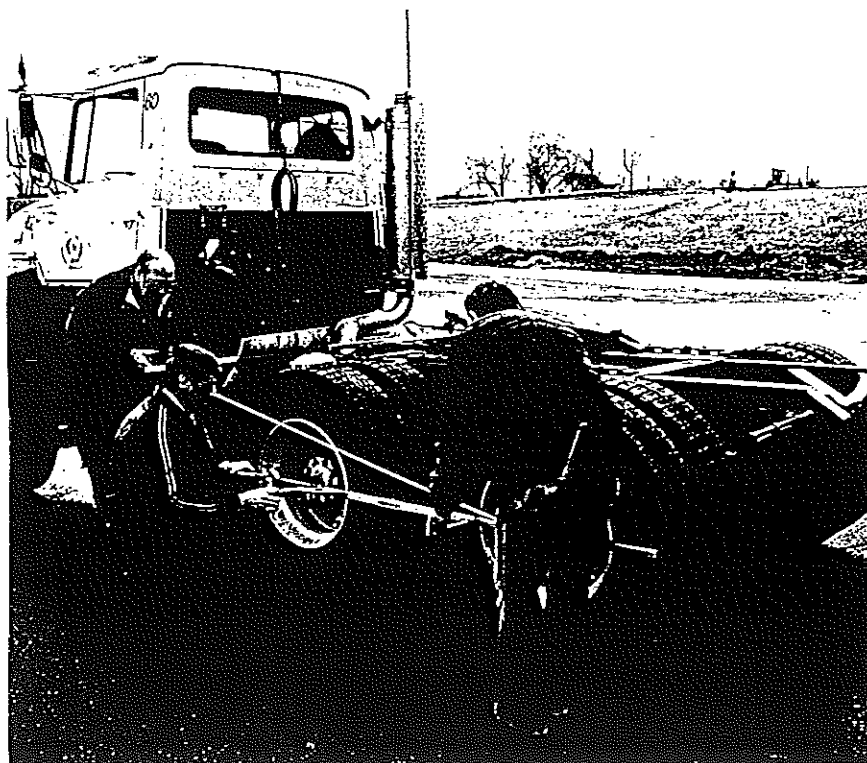

ATTENDANCE LIST
 GENERAL MEMBERSHIP MEETING
 OCTOBER 15-16, 1987
 ORLANDO, FLORIDA

Milton R. Reid	Gainesville
Dan Burek	Sarasota Co.
Vern Tucker	Ocala
John Neal	Pinellas Co.
William Massey	Gainesville
Fred Chester	Temple Terrace
Dexter Martin	Gainesville
Angel Ramos	Gainesville
Robert Stone	Holly Hill
Bob Minton	Tampa
Ron Emery	Holly Hill
Jim Rains	Dunedin
Dave Craft	Altamonte Springs
Bill Harris	Volusia Co.
Richard Collins	Daytona Beach
Wally Brinkman	Hollywood
Ken Friedrichs	Tamarac
Al Biermann	Coral Springs
Gary Giragosian	Boca Raton
Elliott Covo	Miramar
Gene Sorensen	Satellite Beach
RoseAnn Hunter	Seminole Co.
Marvin Van Wormer	Seminole Co.
Clyde Crapo	Seminole Co.
Luis Tamayo	West Palm Beach
Jim Gilhooley	St. Petersburg
Dick Beyer	St. Petersburg
Gene Bugel	Charlotte Co.
James Stephens	Palm Beach Co.
J. Kurt Miller	Pinellas Co.
Buddy Reneau	Apopka
Junior Hurley	Apopka
Jay Dennett	Pinellas Co. Sheriff's Dept.
George Bay	Jacksonville
Bob Smythe	Clairmont
John Crull	Ormond Beach
Bernie Schilling	Ormond Beach
Rick Walke	Ormond Beach
Bob Eichorst	Ormond Beach
Chuck Young	Altamonte Springs

FOR YOUR INFORMATION

AN EDITORIAL BY MR. KURT MILLER - I have to admit I was somewhat let down during our last speaker's remarks on specifications in our October meeting.

At best, the speaker's remarks were conciliatory but offered little to the solution of getting what we need when approaching the specification writing process.

Following are some thoughts and information that may help you.

There is an old adage, "The price is long forgotten after the quality is remembered." If the buyer would keep this in mind before all purchases, eventually all shoddy products would disappear from the marketplace.

In government as well, I cannot believe a councilman or board member would award a low bid if there were any doubt in his or her mind as to the quality of the product. If a fleet manager sees a faulty piece of equipment enter the bid system, it is his responsibility to see the proper documentation is prepared and disseminated to the proper people. If those guidelines are followed, along with the widespread knowledge of the following article among your superiors, there is no reason you should ever have to put up with equipment that won't do the job.

This article is a landmark decision from a Federal court, and carries all the clout you will ever need to support your mission in equipment acquisition.

(Please see the article "Or Equal" on page 12.)

MEMBERSHIPS - With the election of RoseAnn Hunter to the office of secretary/treasurer, we have a new address to mail applications to. It is:

FLORIDA ASSOCIATION OF GOVERNMENTAL FLEET ADMINISTRATORS
C/O Ms. RoseAnn Hunter, Director
Seminole County Fleet Management Department
4340 S. Orlando Drive
Sanford, Florida 32771

And remember - Regular dues are now \$15.00 and Associate dues are \$25.00.

ASSOCIATE MEMBERSHIPS - It is the belief of the Executive Committee that the Association should aggressively solicit associate memberships as a substantial source of revenue. While there is recognition of

concerns that the association must not lose its governmental soul, our By-Laws (Article IV, Section 1.) sufficiently preserve the regular members' right to majority. Nearly all progressive (and successful) associations have a large associate membership and co-exist without conflict.

MORE ABOUT MEMBERSHIPS - The Association has reached 110 memberships and that's a significant achievement. That means that we've got more people than ever to bring new members into the FAGFA. Take the time and make the effort to contact other governmental agencies or private businesses and get them signed up! There's no way around the fact that the more members we have, the more we can accomplish. There are those that need to be asked just one more time and there are those who'll be grateful to know that there's a great association that they can join.

TRAINING/DATA CLEARING HOUSE - C.S. McKay, formerly of Hillsborough County, has left his employ there for parts unknown. His former superior, Mr. Gene Roberts, Director of Fleet Management and Utilization for Hillsborough County, cannot locate any data that Mr. McKay might have put together. The association is therefore in need of another willing and able member to step forward and accept this responsibility. (Based upon their expressed interest in this project, both Kurt Miller and Dan Burek would be the principles to contact on this matter.)

BE ADVISED - When FAGFA "blocks" rooms for us at the Hilton, the rate is \$50.00 per room. If you (as an individual government official) reserve a room while on unspecified business in the area, the rate is \$37.50! FAGFA regrets to inform you that rooms will no longer be "blocked" in its name due to the press of weightier matters, and the Executive Committee begs your understanding of this change. P.S. - Don't forget to bring along a copy of your agency's tax exemption.

SPECIFICATIONS - Kurt Miller and several others will generously give of their expertise with the preparation of specifications and what goes on behind a successful bid effort. This two-hour session on April 22nd promises to take you on a very educational trip through the specifics of specifications.

REMEMBER - If you know of some event or development that may be of interest to our membership, take the opportunity to share it. All you have to do is write or call the Fleet Line editor, Vern Tucker, and give him the news. It will, if possible, appear in the next issue under this column. Transfers, retirements, job openings, technical information, and management helps are the types of information we want.

THE CRITICAL WEAKNESS - Strategic thinking and operational planning:

<u>CONDITIONS</u>	<u>VALUE</u>
Clear Strategy & Operational Effectiveness	A+
Unclear Strategy & Operational Effectiveness	B-
Clear Strategy & Operational Ineffectiveness	C-
Unclear Strategy & Operational Ineffectiveness	D-

Or Equal

Federal Court Says "Or Equal" Up To Specifying Source!!

Affirming a decision handed down by the U.S. District Court of Massachusetts, the Federal 1st Circuit Court in the case of *Whitten Corp. vs Paddock, Inc.*, was backed up by the U.S. Supreme Court which several weeks ago refused to hear further appeals. The decision is unique in that it defines the specifying party's clear authority at the federal level where previous decisions have been in lower courts.

Four major rulings regarding specifications come from this landmark decision:

1) The court ruled that proprietary specifications are not a violation of anti-trust laws. Further, the court stated that trained professionals — specifiers — make informed judgments on products which they feel best serve their client's needs. Technically, few brands of materials or equipment are exactly alike, and if the specifier wants to limit the specification to one source he has the right to do so and to enforce it.

2) The court ruled that other suppliers or manufacturers can qualify as "Or Equal" only when the specifier chooses to waive specifications or permit those suppliers or manufacturers to bid.

However, it clearly stated that the specifying source is charged with the responsibility and judgment for determining whether a proposed substitution is an "Or Equal". Further, where "Or Equal" is not stated in the specifications, it is still the specifying source's decision as to what products do or do not qualify as "Or Equal".

3) The court stated that the specifier "... may waive specifications in order to obtain a more desirable product for the client". The implication is again that only the specifier (from start to finish of the construction process) can ultimately decide that another desirable product is available in lieu of the product originally specified in the client's best interest.

4) The court concluded "the burden is on the supplier or manufacturer who has not been specified to convince the specifier that their product is equal for the purpose of a particular project."

This is probably one of the most powerful court judgments in construction law history to come down the road — in that the judgment now establishes the specifier's legal right toward brand selection. It should also merit very important consideration for those manufacturers that desire to make a better quality product and thereby get paid the necessary price to stay viable with it.

RUMOR HAS IT - There's a position opening in Charlotte, NC. Fleet Managers looking for a a job in those parts paying upwards of 50 G's a year out to check out this hot tip!

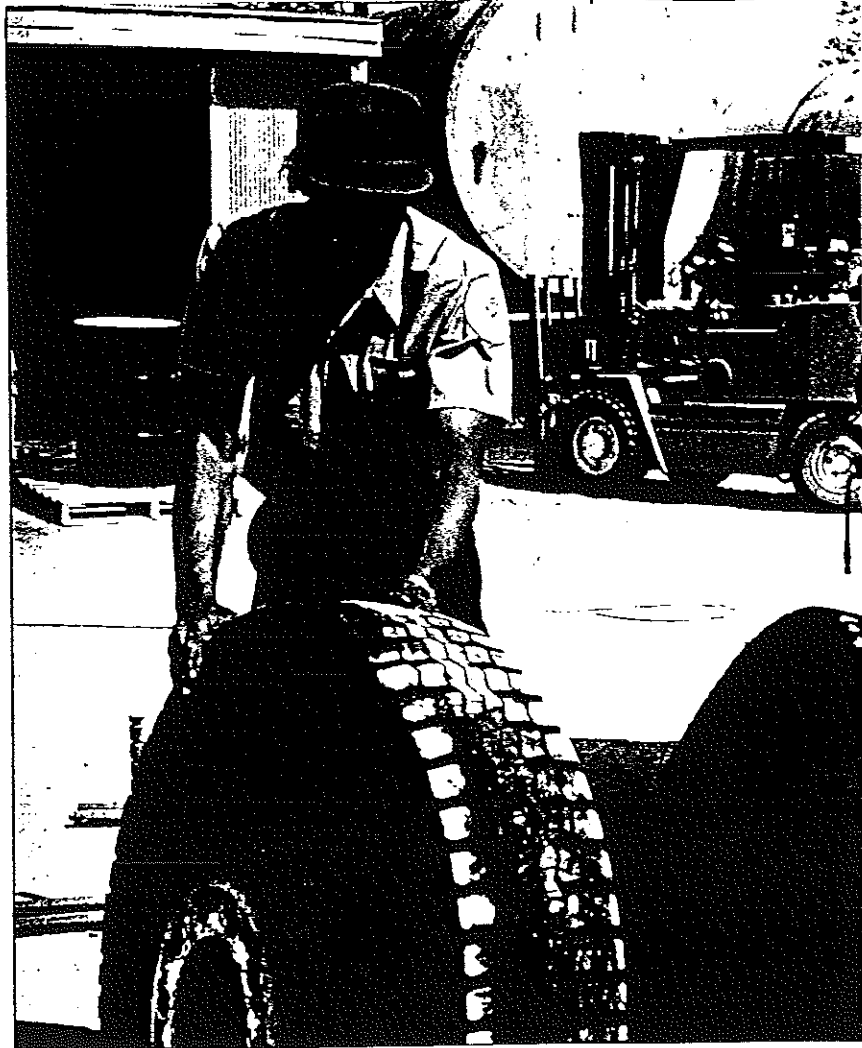

FLORIDA ASSOCIATION OF GOVERNMENTAL FLEET ADMINISTRATORS
PROPOSED AGENDA FOR THE APRIL 1988 GENERAL MEMBERSHIP MEETING

Hilton Inn Florida Center
 7400 International Drive
 Orlando, Florida

Ficus Room

21 & 22 April 1988

THURSDAY, 21 APRIL, 1988

8:30 a.m. - 8:55 a.m.	Registration
8:55 a.m. - 9:00 a.m.	Opening Remarks
9:00 a.m. - 10:00 a.m.	<u>Computerized Fleet Maintenance Systems.</u> To be presented by Jim Nelson, Vice President of C.C.G. Systems, Portsmouth, Virginia. (804) 393-4383.
10:00 a.m. - 10:15 a.m.	Break
10:15 a.m. - 11:30 a.m.	<u>Aerial Equipment Maintenance Safety Regulations.</u> To be presented by Allan W. Fyfe, Manager-Service Center, Baker Equipment Engineering Company, West Palm Beach, Florida. (305) 471-5400.
11:30 a.m. - 1:00 p.m.	Lunch
1:00 p.m. - 2:00 p.m.	<u>Shop Management/Shop Productivity.</u> To be presented by Patrick Murphy, President of Murphy and Associates, Fleet Management Consultants, Houston, Texas.
2:00 p.m. - 3:00 p.m.	Rap Session
3:00 p.m. - 3:15 p.m.	Break
3:15 p.m. - 4:00 p.m.	<u>Fire Equipment Specifications and Special Maintenance Needs.</u> To be presented by Mr. Al Weaver of Emergency One, Ocala, Florida (904) 237-1122.
4:00 p.m. - 5:00 p.m.	Business Meeting

FLORIDA ASSOCIATION OF GOVERNMENTAL FLEET ADMINISTRATORS
PROPOSED AGENDA FOR THE APRIL 1988 GENERAL MEMBERSHIP MEETING

(Continued)

FRIDAY, 22 APRIL 1988

8:30 a.m. - 10:30 a.m.	<u>Making Sense of Specifics.</u> To be presented by Mr. Kurt Miller, Director of Fleet Management for Pinellas County, Florida. (813) 462-4832.
10:30 a.m. - 10:45 a.m.	Break
10:45 a.m. - 11:30 a.m.	Rap Session
11:30 a.m. - 1:00 p.m.	Lunch
1:00 p.m. - 3:00 p.m.	Rap Session
3:00 p.m. - 4:00 p.m.	Executive Committee Meeting

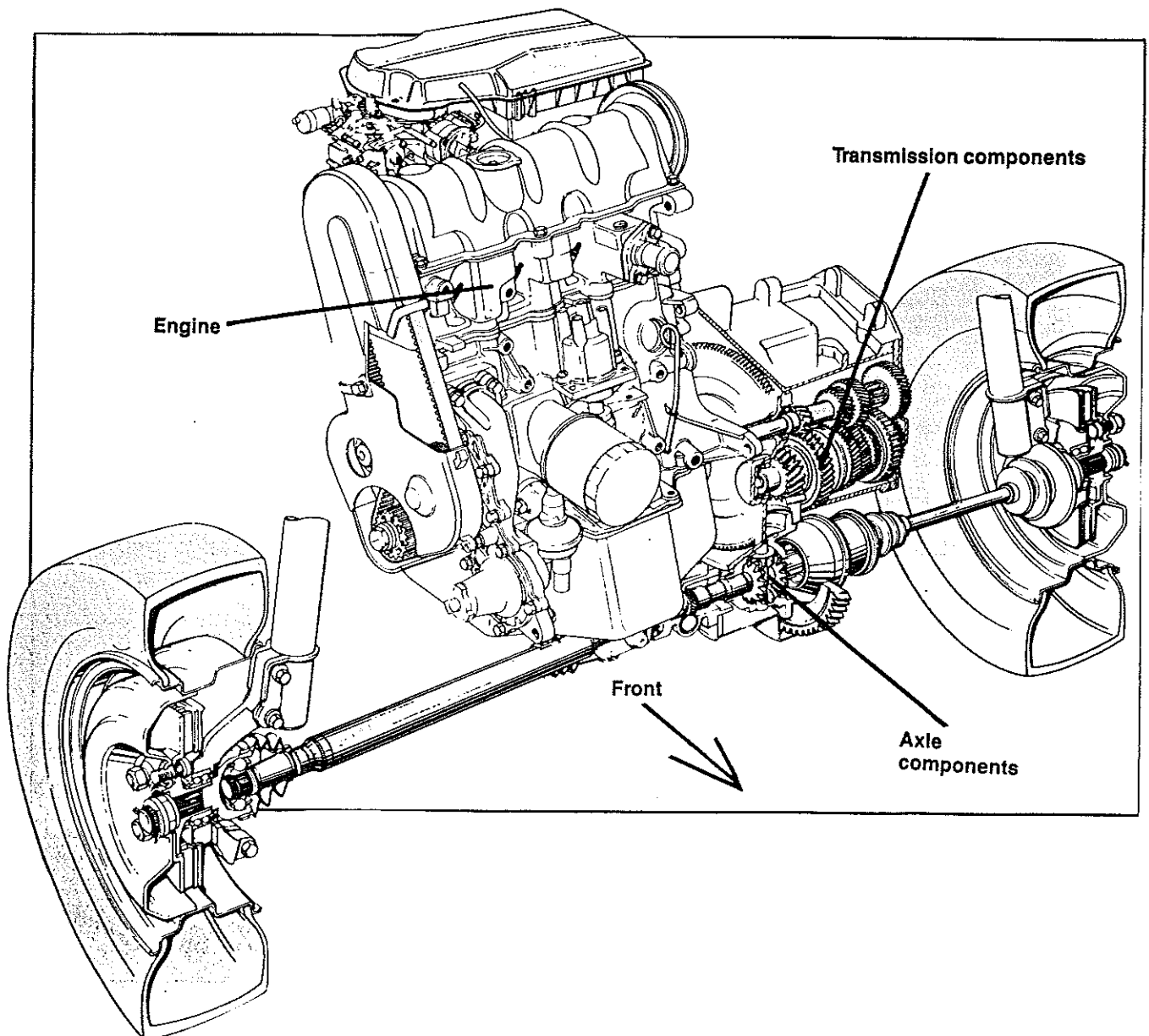

As of: January 15, 1988

Mr. Cesar Abrajano
Senior Administrative Asst.
City of Jacksonville
3336 Debusay Road
Jacksonville, FL 32211
(904) 384-1100

Mr. Richard Miller **
Division Manager
Pasco County Fleet Maintenance
ARA Services Managed Logistics Sys.
8835 Government Drive
New Port Richey, FL 33553
(904) 384-1100

Mr. George Arnold, III
Equipment Management Superintendent
Broward County Equip. Mgmt Div.
5th Floor, 115 S Andrews Ave
Ft. Lauderdale, FL 33301
(305) 258-5247

Mr. George Bay
Equipment Supervisor
City of Jacksonville
2581 Commonwealth Ave.
Jacksonville, FL 32205
(904) 786-6358

Mr. Gerald Beduch, Sr.
Equipment Maint. Supv.
City of Hallandale
630 N.W. 2nd St.
Hallandale, FL 33009
(305) 458-3251 X233

Mr. Albert Biermann
Equipment Superintendent
City of Coral Springs
9551 W Sample Road
PO Box 754501
Coral Springs, FL 33075-4501
(305) 344-1180

Mr. Tom Blanks
Fleet Maint. Operations Coord.
Metro-Dade County GBA
Fleet Mgmt Dept
Suite 2530, 111 NW 1st St
Miami, FL 33128-1979
(305) 375-2285

Mr. John Booher
Supt Equip & Vehicle Maint.
Solid Waste Auth of Palm Bch Co
5114 Okeechobee Blvd, Suite 2C
West Palm Beach, FL 32301
(305) 969-1897

Mr. John Booth
Fleet Coordinator
City of Tallahassee
City Hall
Tallahassee, FL 32301
(904) 576-5171

Mr. Richard Boyer
Manager, Contracts & Services
City of St. Petersburg
1800 7th Ave, North
St. Petersburg, FL 33713
(813) 893-7147

Ms. Phyllis Brashell
Fleet Mgt. Superintendent
Broward County Equip Mgt Div
115 S Andrews Ave, Rm 514
Ft. Lauderdale, FL 33301
(305) 357-6498

Mr. Gene Bragel
Supt. of Vehicle Maint
Charlotte County
7000 Florida Ave
Punta Gorda, FL 33950
(813) 625-5770

Mr. Henry Brewer
Senior Buyer
Gainesville, Fleet Management
87A, 54, PO Box 490
Gainesville, FL 32602
(904) 374-2848

Mr. Hally Brinkman
Supt. of Fleet Maintenance
City of Hollywood
1801 N 21st St
Hollywood, FL 33020
(305) 921-3032

Mr. Dan Burke
Director, Fleet Mgt. Div.
Barrasota County
4310 Ashton Road
Barrasota, FL 33583
(813) 924-3352

Mr. Allen Cook
Equipment Maint. Supt.
City of Deerfield Beach
150 N.E. 2nd Ave
Deerfield Beach, FL 33441
(305) 427-3331

Mr. Gordon Causey **
President
Equipment Consultants, Inc.
9793 S Orange Blossom Trail
Orlando, FL 32821
(305) 855-0211

Mr. Fred Chester
Garage Supervisor
City of Temple Terrace
6009 Whiteway Dr.
Temple Terrace, FL 33517
(813) 989-7170

Mr. Berald Clark
Director
Citrus County Public Works Dept
PO Box 440
Leucanto, FL 32661
(904) 746-2694

Mr. Richard Collins
Equipment Manager
City of Daytona Beach
PO Box 551
Daytona Beach, FL 32015
(904) 258-3193

Mr. William Conaway
Supervisor, Vehicle Maint.
City of West Palm Beach
1045 Charlotte
West Palm Beach, FL 33402
(305) 582-0475

Mr. Clive Cork
Fleet Superintendent
City of North Miami
1855 N.E. 142nd St
North Miami, FL 33161
(305) 949-7354

Mr. Elliot Covo
Chief Mechanic
City of Miramar
7000 Miramar Parkway
Miramar, FL 33023
(305) 969-6210 X275

Mr. David Craft
Shop Superintendent
City of Altamonte Springs
225 Newburyport Ave
Altamonte Springs, FL 32701
(305) 862-8221

Mr. Dennis Crosby
Division Chief
City of Jacksonville
2581 Commonwealth Ave
Jacksonville, FL 32205
(904) 3384-1100

Mr. Jon Crull
Fleet Maint. Supervisor
City of Port Orange
PO Box 5
Port Orange, FL 32019
(904) 761-8000

Mr. B.H. "Bud" Dawson
Fleet Service Manager
Marion County Sheriff Dept.
PO Box 1987
Ocala, FL 32678
(904) 622-3331

Mr. James DeMay
Fleet Superintendent
City of Tallahassee
City Hall
Tallahassee, FL 32301
(904) 576-5172

Mr. A. Jay Dennett
Shop Supervisor
Pinellas County Sheriff's Dept
250 Ulmerton Rd.
Largo, FL 33540
(813) 587-6319 or 587-6200

Mr. Ronald J. Ehmer
Superintendent
Walt Disney World
PO Box 10150
Lake Buena Vista, FL 32830-0150

Mr. Robert Eichorst
Asst. Director, Public Works
City of Boynton Beach
PO Box 310
Boynton Beach, FL 33435
(305) 734-8111 X424

Mr. Ronald Emery
Director of Public Works
City of Holly Hill
453 11th St.
Holly Hill, FL 32017
(904) 255-2531

Mr. Richard Evans
Fleet Acquisitions Supv.
City of Tampa Fleet Maint.
1508 North Clark Ave
Tampa, FL 33607
(813) 877-0566 X205

Mr. James Flood
Director
Broward County Equip, Mgt Dept
115 South Andrews Ave, Rm 514
Ft. Lauderdale, FL 33540
(305) 357-6499

Mr. Ken Friedrichs
Superintendent/City Garage
City of Tamaraac
5650 N.W. 88th Ave
Tamaraac, FL 33321
(305) 722-4210, 721-0470

Mr. Joe Fuhrmann
Garage Superintendent
City of Jacksonville, Fleet Dept
2581 Commonwealth Ave
Jacksonville, FL 32205
(904) 387-8800

Mr. Don Gardner
Automotive Service Manager
Ft. Lauderdale Public Works
PO Box 14250
Ft. Lauderdale, FL 33302
(305) 761-5756

Mr. Gary Giragonian
Service Manager
City of Boca Raton
2500 N.W. 1st Ave
Boca Raton, FL 33431
(305) 393-7889

Mr. Mark Glaiber
Director, Fleet Mgt. Div.
Metro-Dade County
111 NW 1st St
Miami, FL 33128
(305) 375-2204

Mr. Earnest Hower
Garage Supervisor
City of Plantation
400 NW 73rd St
Plantation, FL 33317
(305) 797-2158

Mr. Mark Hamilton
Fleet Maint Op. Coordinator
Metro Dade County GBA Fleet Dept
111 NW 1st St, Suite 2530
Miami, FL 33128
(305) 375-2288

Mr. Michael Harris
Vehicle Maintenance Supv.
City of Dania
100 W Beach St.
Danial, FL 33004
(305) 921-8700 X305

Mr. William Harris
Vehicle Maintenance Supt.
County of Volusia
1501 Bellevue Ave PO Box 367
Daytona Beach, FL 32015
(904) 255-4695

Mr. James Higginbotham
Public Works Director
City of Fernandina Beach
PO Box 668
Fernandina Beach, FL 32034
(904) 261-6173

Mr. Ivey Hill
Asst. Fleet Supt.
City of Tallahassee
City Hall
Tallahassee, FL 32301

Mr. Jim Hinds
Dir, Dept of Public Works
City of Margate
5790 Margate Blvd
Margate, FL 33063
(305) 972-8126

Mr. Arthur Hoelderlin, Jr.
Supt./Public Works Dept
City of Margate
5790 Margate Blvd.
Margate, FL 32063
(305) 972-8126

Ms. RoseAnn Hunter
Director
Seminole Co. Fleet Mgmt.
4340 S Orlando Dr.
Sanford, FL 32773
(305) 323-2500 X135

Mr. Douglas Hutchins
Director, Fleet Management
City of Jacksonville
2581 Commonwealth Ave
Jacksonville, FL 32205
(904) 384-1100

Ms. Marsha Jackson
Fleet Unit Administrator
Metro Dade County BSA Fleet Div
111 NW First St.
Miami, FL 33128
(305) 375-5139

Mr. R. Aaron Jordan
Chief, Engineering Svcs
State Division of Forestry
3125 Connor Blvd
Tallahassee, FL 32301
(904) 488-4263

Mr. Phil King
Shop Supervisor
Highlands County Road Dept
4344 George Blvd
Sebring, FL 33870
(813) 382-5294, 385-2581 X339

Ms. Martha Lacy
Project Officer
Orange County Sheriff's Office
PO Box 1440
Orlando, FL 32802
(305) 420-3013

Mr. Jay Leffert
Cmndr. Logistical Support Bureau
Orange County Sheriff Office
PO Box 1440
Orlando, FL 32802
(305) 420-3946

Mr. Daniel Leirer
Service Manager
Metro Sarasota Fire Rescue
2200 Stickney Point Road
Sarasota, FL 33581
(813) 923-5964

Mr. Robert Leslie **
Vice President
Delta Mobile Testing, Inc.
PO Box 307
Buckner, KY 40010
(502) 222-1797

Mr. John Lettow
Dir. of Municipal Services
City of Crystal River
123 NW Highway 19
Crystal River, FL 32629
(904) 795-4216

Mr. Donald Long
Asst. Fleet Admin.
City of Clearwater Motor Pool
PO Box 4748
Clearwater, FL 33518
(813) 462-6833

Mr. Richard Losinski
Asst. Fleet Mgr., Operations
City of Tampa
1508 North Clark Ave
Tampa, FL 33607
(813) 877-0566 X241

Ms. Billie Mack
Fleet Division/Admin Aide
City of Tallahassee
City Hall
Tallahassee, FL 32301
(904) 576-5171

Mr. Lawrence Mandelion
Chief Mech., Public Works Dept
City of Margate
5790 Margate Blvd
Margate, FL 32063
(305) 972-8126

Mr. William Massey
Fleet Svcs. Superintendent
City of Gainesville
400 SE 5th Ave
Gainesville, FL 32601
(904) 374-2978

Mr. Doug Mattocks
Operations Mgr. Veh. Maint
Volusia County Veh Maint.
1501 Bellvue Ave
Daytona Beach, FL 32014
(904) 749-2850

Mr. Carnel Mays
Engineering Tech II
City of Jacksonville
515 West 6th St
Jacksonville, FL 32206
(904) 633-3415

Mr. Jack McCoy
Chief Mechanic
City of Pembroke Pines
10211 Taft St.
Pembroke Pines, FL 33026
(305) 981-7144

Mr. C. B. McKay
General Manager IV
Hillborough County Fleet Mgt
1205 Orient Road
Tampa, FL 33619
(813) 623-2485

Mr. David Means
Supervisor
Municipal Maint Dept, Mech Div
1800 7 Ave N
St. Petersburg, FL 33713
(813) 893-7834

Mr. Timothy Messenger **
Fleet Manager
Manatee County/Roy Jorgensen Asso
PO Box 10723, 57th Ave Branch
Bradenton, FL 33505
(813) 748-0944

Mr. John Kurt Miller
Director, Fleet Mgmt
Pinellas County
1333 Ulmerton Road
Largo, FL 33541
(813) 462-4832

Mr. Victor Minotty
City Garage Supt (RET)
City of Palmpino Beach
PO Drawer 1300
Palmpino Beach, FL 33060
(305) 786-4109

Mr. Richard Minster
Director of Public Works
City of Sarasota
1761 12th St
Sarasota, FL 33577
(813) 365-2200 X229

Mr. James Moore **
Fleet Sales Mgr
Barlow Ford Company
425 E Van Fleet Drive
Bartow, FL 33820
(813) 533-0425

Mr. John Neal
Fleet Analyst
Pinellas County
1333 Ulmerton Road
Largo, FL 33541
(813) 462-4832

Mr. John Niederhauser
Fleet Manager
City of New Smyrna Beach
210 Bams Ave
New Smyrna Beach, FL 32069-9985
(904) 427-4166 X74

Mr. George Odow
Service Manager
City of New Smyrna Beach
210 Bams Ave
New Smyrna Beach, FL 32069-9985
(904) 427-4166 X74

Mr. Bruce T. Page
Eqpt Cont/Vehicle Maint Super.
City of Hialeah Police Dept
824 84th St
Miami Beach, FL 33141
(305) 866-3105

Mr. Porter Pallatt
Director, Fleet Mgmt (RET)
Hillborough County
1205 Orient Road
Tampa, FL 33619
(813) 272-6731

Mr. Tom Picard
Director of Central Services
11 N 3rd St.
Jacksonville Beach, FL 32250
(904) 249-2381 X225

Mr. Jerry Plummer
Equipment Maint Super.
City of South Daytona
1770 Seagrave St.
South Daytona, FL 32019
(904) 767-3025

Mr. Vaden Pollard
Road & Bridge Director
Highlands County Road Dept
4344 George Blvd
Sebring, FL 33870
(813) 382-5294

Mr. Johnny Pompey
Fleet Manager
Leon County Fleet Div
2280 Miccookee Road
Tallahassee, FL 32308
(904) 487-3075

Mr. Larry Raby
Shop Manager
Bolid Waste Auth/Palm Bch Co.
514 Oksechobee Blvd Suite 2C
West Palm Beach, FL 33409
(305) 969-1897

Mr. James Rains
Div. Director of Maint.
City of Dunedin
750 Milwaukee Ave
Dunedin, FL 33528
(813) 733-4151 X250

Mr. Angle Ramos
Fleet Service Supt.
City of Gainesville
405 NW 39th Ave
Gainesville, FL 32602
(904) 374-2258

Lt. Jimmie Randle
Supv. Fleet Maint Section
Orange County Sheriff's Office
PO Box 1400
Orlando, FL 32802
(305) 291-0023

Mr. Fermin Rodriguez
Fleet Acquisitions Specialist
City of Tampa
1508 N Clark Ave
Tampa, FL 33607
(813) 877-0566 X206

Mr. Rowland Ranger
Chief Mechanic
City of Cooper City
11531 SW 49th St
Cooper City, FL 33330
(305) 434-2300

Mr. Deane Ragis
Director of Support Services
City of Deerfield Beach
150 NE 2nd Ave
Deerfield Beach, FL 33441
(305) 427-3331

Mr. Milton Reid
Fleet Manager
City of Bainesville
PO Box 490 ATTN: Bta. 51
Bainesville, FL 32602
(904) 374-2251

Mr. Klaus Reinhard
Fleet Superintendent
City of Pompano Beach
1190 NE 3rd St
Pompano Beach, FL 33061
(305) 786-4109

Mr. Bernhardt Schilling
Service Manager
City of Ormond Beach
298 Towoka Ave
Ormond Beach, FL 32074
(904) 677-0311 X265

Mr. Gregory Schmidt
Supt. Equip Maint
City of Melbourne
900 E Stranbridge Ave
Melbourne, FL 32901
(305) 725-9145

Mr. James Sherman
Director of Public Works
City of Coconut Creek
4800 W Copan's Road PO Box 4007
Coconut Creek, FL 33063
(305) 973-6780

Mr. George Bindelar
Department Manager
Orange County Vehicle Maint.
2450 33rd St.
Orlando, FL 32809
(305) 420-3801

Mr. Robert Baythe
Dir. of Public Works/Fire Chief
City of Clermont
PO Box 819
Clermont, FL 32711
(904) 394-3350

Mr. Gene Boransen
Public Works Director
City of Bataillite Beach
510 Cinnamon Drive
Bataillite Beach, FL 32937
(305) 777-2309

Mr. Tom Bova
Equipment Maint. Specialist
City of Boca Raton Fire Dept
2333 W Glades Road
Boca Raton, FL 33431
(305) 391-9804

Mr. John Stafford
Fleet Administrator
City of Clearwater
PO Box 4748
Clearwater, FL 33518
(813) 462-6833

Mr. Charles Swarans
Asst. Fleet Mgr. Admin
City of Tampa Fleet Maint
1508 N Clark Ave
Tampa, FL 33607
(813) 877-0566 X210

Mr. Luis Tawayo
Director of Vehicle Maint.
City of West Palm Beach
1045 Charlotte Ave
West Palm Beach, FL 33401
(305) 659-8035

Mr. Gary Templeton **
Secretary/Treasurer
Equipment Consultants, Inc.
9793 B Orange Blossom Trail
Orlando, FL 32821
(305) 855-0211

Mr. James Thomas
City of Miami, GSA Property Main
1975 NW 18th Ave
Miami, FL 33136

Mr. Vernon Tucker
Director of Fleet Mgt.
City of Ocala
2100 NE 30th Ave
Ocala, FL 32670
(904) 351-6754

Mr. Duane Vandenberg
Fleet Manager
City of Tampa Fleet Maint.
1508 N Clark Ave
Tampa, FL 33607
(813) 877-0566 X200

Mr. Richard Walke
Asst. Dir of Public Works
City of Ormond Beach
298 Tomoka Ave
Ormond Beach, FL 32074
(904) 677-0311 X221

Mr. Douglas Weichman
Fleet Maintenance Div Mgr.
Metro Dade County GSA Fleet Dept
701 NW 25th St
Miami, FL 33127
(305) 638-6487

Mr. Ron Williams
Director
City of Miami, GSA Dept
1390 NW 20th
Miami, FL 33142
(305) 579-6740

Mr. W.C. Williams
Director, Municipal Maint
City of St. Petersburg
1800 7th Ave N.
St. Petersburg, FL 33713
(813) 893-7469

Mr. John Worsham
Bureau Chief
City of Orlando
1000 W Gore St
Orlando, FL 32805
(305) 849-2302

Mr. Charles Young
Bupt. of Fleet Maint
City of Altamonte Springs
497 West Drive
Altamonte Springs, FL 32701
(305) 862-8221

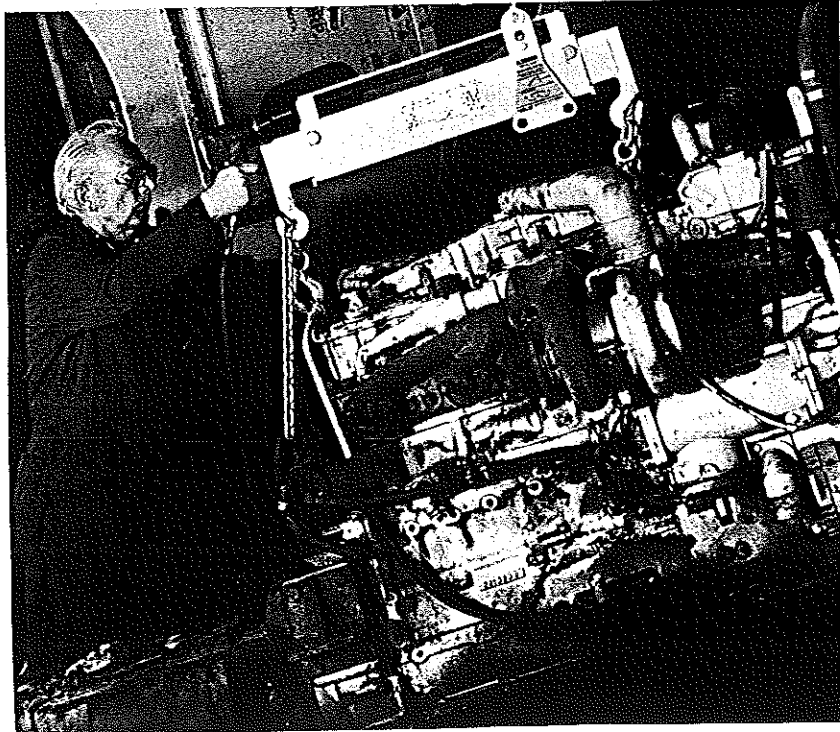

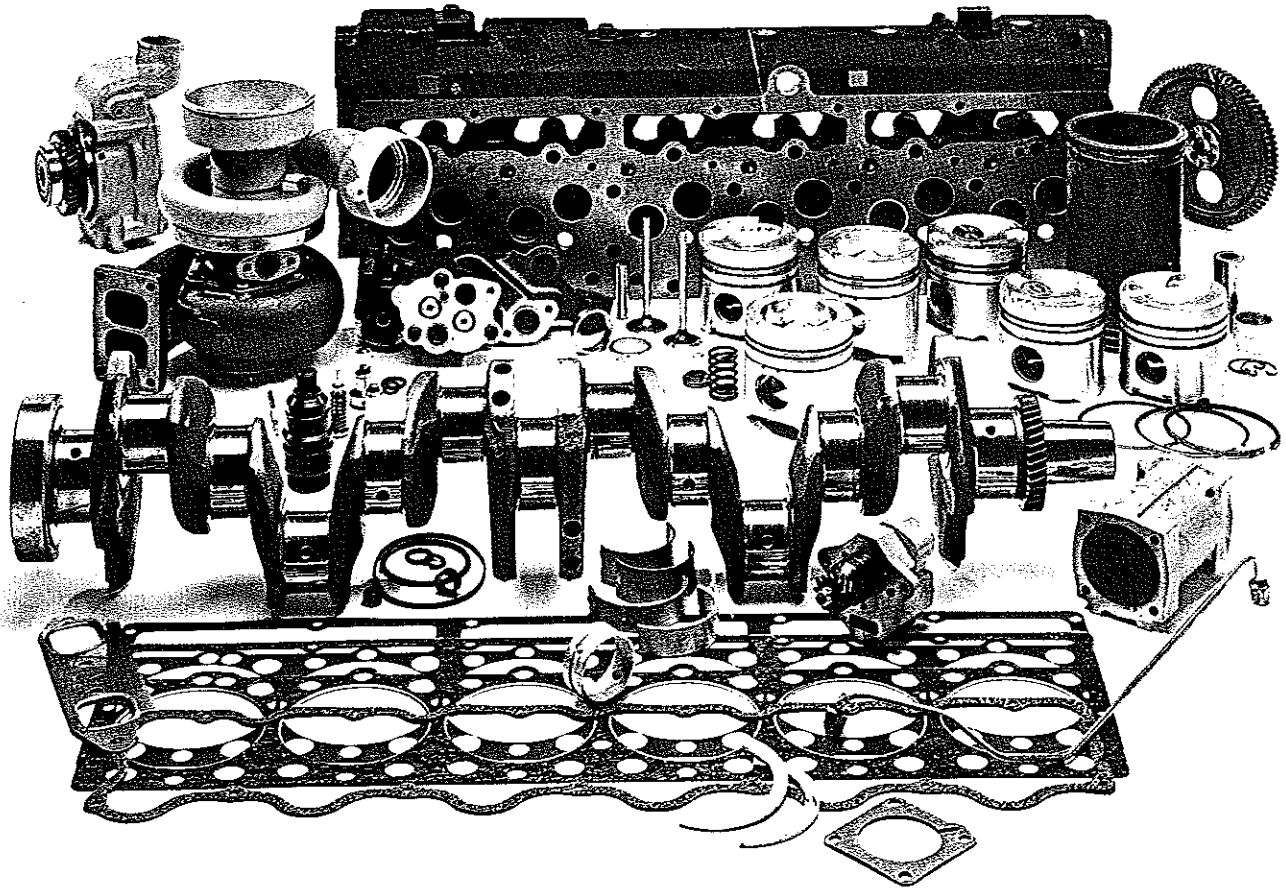

Everything requires time. It is the one truly universal condition. All work takes place in time and uses up time. Yet most people take for granted this unique, irreplaceable, and necessary resource. Nothing else, perhaps, distinguishes effective executives as much as their tender loving care of time.

PETER DRUCKER

Common sense is instinct, and enough of it is genius.

JOSH BILLINGS

APPLICATION FOR MEMBERSHIP

FLORIDA ASSOCIATION OF
GOVERNMENTAL FLEET ADMINISTRATORS

19

TO THE TREASURER AND SECRETARY:

Date: _____

Name: _____

Title: _____

MAILING ADDRESS: _____

_____ Zip _____

Area Code and Phone Number: _____

Representing: _____

BUSINESS
ADDRESS: _____

_____ Zip _____

TYPE OF GOVERNMENTAL UNIT: _____
(Municipality, County, State, Federal, or Other)

Number of years in current position: _____

Number of years in governmental fleet operations: _____

SIGNATURE of APPLICANT

Date _____

Approved: _____
TREASURER

Date _____

ANNUAL MEMBERSHIP DUES: Regular: \$15.00 Associate: \$25.00

Enclose check or money order payable to the FLORIDA ASSOCIATION OF
GOVERNMENTAL FLEET ADMINISTRATORS.

FLORIDA ASSOCIATION OF GOVERNMENTAL FLEET ADMINISTRATORS
C/O Ms. Rose Ann Hunter, Director
Seminole County Fleet Management Department
4340 S. Orlando Drive
Sanford, Florida 32771