

FLEET LINE

OFFICIAL NEWSLETTER OF THE
FLORIDA ASSOCIATION OF GOVERNMENTAL
FLEET ADMINISTRATORS, INC.

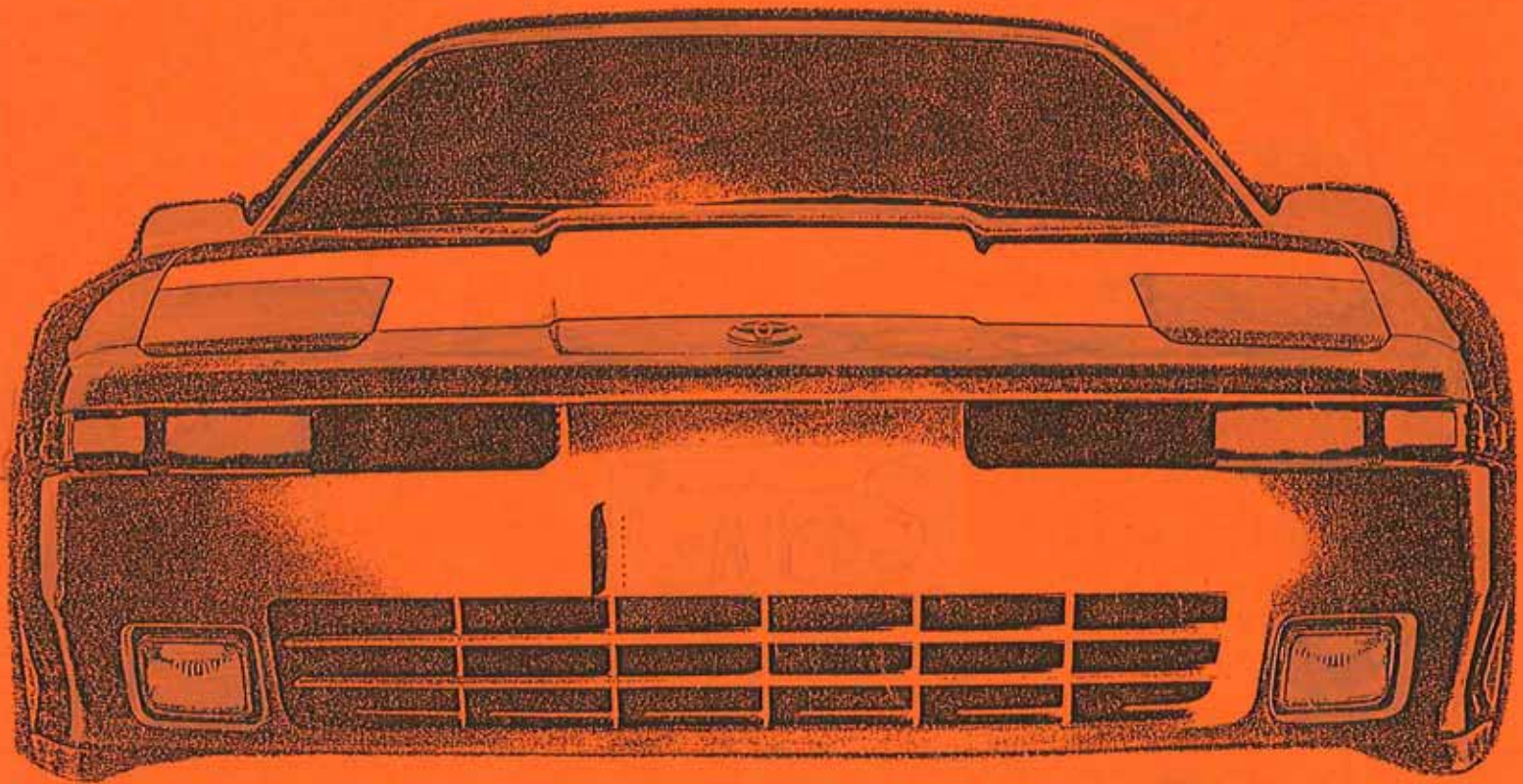

THIS NEWSLETTER IS A PUBLICATION OF THE FLORIDA ASSOCIATION OF GOVERNMENTAL FLEET ADMINISTRATORS (FAGFA) AND IT IS PUBLISHED TO KEEP FAGFA MEMBERS INFORMED ABOUT THE ASSOCIATION'S ACTIVITIES AND OTHER MATTERS OF INTEREST TO FLEET MANAGERS. THE FAGFA HOPES TO PUBLISH THIS NEWSLETTER, AT A MINIMUM ON A BIENNIAL BASIS.

F.A.G.F.A. OFFICERS

PRESIDENT	JON CRULL	(904) 676-3265	ORMOND BEACH
1st V.P.	JOHN D. WARBINGTON	(407) 836-7800	ORANGE COUNTY
2nd V.P.	JAMES M. AGGELES	(813) 588-8150	PINELLAS COUNTY
SECRETARY	RICHARD EVANS	(813) 878-1004	CITY OF TAMPA
TREASURER	SHARAN D. FOSBINDER	(407) 836-7800	ORANGE COUNTY

EDITOR/ILLUSTRATOR	James M. Aggeles
ASSISTANT EDITOR	Teddie B. Aggeles

SHOULD ANY REPRODUCTION OF THIS PUBLICATION BE DESIRED FOR USE BY ANY INDIVIDUAL OR AGENCY OTHER THAN THE FAGFA OR ITS MEMBERS, THE EDITOR MUST BE CONTACTED FOR PERMISSION TO DO SO.

TABLE OF CONTENTS	PAGE
FROM THE PRESIDENT	1
MINUTES (APRIL 1992)	2
TREASURER'S REPORT	7
ATTENDANCE (APRIL 1992)	8
FOR YOUR INFORMATION	9
PROPOSED AGENDA (SEPT. 1992)	10
MEMBERSHIP ROSTER (ACTIVE)	12
ASSOCIATE MEMBERSHIP ROSTER	20
FAGFA MEMBERSHIP APPLICATION FORM	22

FROM THE PRESIDENT

HELP!

I hear this cry almost every day from Fleet Administrators all over the United States. Privatization of public fleets is not decreasing....it seems to be on the rise and it affects each and everyone of us in some way. Since our last FAGFA meeting my City has formed a citizens committee to review the operations of every department. Mine has been scrutinized by a group of eight individuals. I had to bare my very soul for almost two hours while each one of these people took their turn at questioning my operation. They seemed to be open minded and hopefully I was able to justify our existence. Their report will be released sometime in September, possibly during the time I am at this meeting.

Not every Fleet Administrator gets the opportunity as I did to explain, justify, and hopefully convince the "Powers To Be" about their operation. All too often it becomes a political bullring and the sweet talking privateer with their promises to save the all mighty dollar prevails.

My advice is this. Start to prepare now "today" for the eventual examination of your operation. It is not a matter of if any more, it is a simply a matter of **when** is it going to be done. Scrutinize your own operation like it is a life threatening situation. Start with yourself and ask "Am I doing all I can do to make this the most efficient...effective operation possible?" Put yourself into a position whereby if a privateer knocks on your door, you can look them straight in the eye and say: "Good luck pal, because we are going to play this game by my rules, not yours!"

Unfortunately or maybe fortunately our role as a fleet administrator has evolved from the best wrench turner getting the job; to the best combination of manager, leader, businessman, attorney, environmentalist, marketer and public relations person being chosen to administer a fleet operation. It almost doesn't matter any more if you personally know how to fix a vehicle. What matters is the fact that you can track and repair it from birth to death and keep your costs as low as possible while it is in your fleet. Over simplified, yes, but this is the basic reason each of us has a job.

This Association has given us the ability to interact with each other and learn what we need to do to keep our costs low, our productivity high, and our jobs secure. I cannot thank the membership enough for that opportunity.

Good luck to each of you as we enter our new fiscal year. It promises to be extremely interesting as usual.

Jon Crull

OFFICIAL MINUTES

FLORIDA ASSOCIATION OF GOVERNMENTAL FLEET ADMINISTRATORS

General Membership Meeting

Thursday, April 30, 1992

Treasure Island Inn
Daytona Beach Shores, Florida

The April General Membership Meeting was called to order by the Association President, Jon Crull, Fleet Operations Director, City of Ormond Beach, at 9:00 a.m. on April 30, 1992. Jon opened with a discussion about the importance of competitiveness. Following the President's remarks, the attenders introduced themselves. After the introductions were completed, Jon made several announcements; Myers Tire Supply, Miami donated an air impact gun and numerous baseball caps to be awarded as door prizes, Mr. John Wray (407) 281-6977, an Air Force Fleet Manager, would be retiring soon and would be seeking employment, and Jerry Wood of the Southeast Region issued their 'Red Shirt' challenge.

9:10 a.m. - Jon Crull introduced Kelly Walker, President of Kelly Walker & Associates, who gave a presentation on how to "SAVE YOUR JOB!" by improving your fleet management efficiency while remaining cost competitive. Mr Walker identified 10 reasons why fleet department personnel are losing their jobs at record rates and suggested some remedies. Mr. Walker conducted a 15 minute question and answer period to conclude his presentation.

10:15 a.m. - Break

10:30 a.m. - Kurt Miller, Pinellas County, introduced Pinellas County Purchasing Director, Jim Ashman.

10:32 a.m. - Jim Ashman's presentation was postponed temporarily while a member of the hotel staff lead the assemblage in a 'Stretch Break.'

10:35 a.m. - Jim Ashman gave a presentation entitled "Becoming User Friendly With Your Purchasing Department." Mr Ashman stressed the importance of communication, trust, respect, consistency and flexibility in establishing a good rapport with the purchasing organization. Mr. Ashman concluded his presentation with a question and answer session in which Luis Tamayo asked about Pinellas County's experience in purchasing used equipment. A discussion ensued.

11:20 a.m. - Jon Crull thanked the speakers for their presentations. Jon announced that F.A.G.F.A. member Don Hulse, Fleet Manager, Orange County Sheriff's Office, had passed away and asked for a moment of silence in his memory.

11:30 a.m. - Meeting adjourned for lunch.

1:00 p.m. - Jon Crull brought the meeting to order and related an amusing occurrence he and his son had in a line at the bank behind an extremely large woman with a message beeper.

1:05 p.m. - Association Treasurer, Sharan Fosbinder, Orange County, introduced John Warbington, Fleet Manager, Orange County, who gave a presentation titled "Privatization, Competing With The Outside World." Mr. Warbington stressed that fleet manager needed to manage their fleets like a business and not be satisfied with being as good as your competition; be better.

1:55 p.m. - Break.

2:05 p.m. - Fleet Funnies. Kurt Miller told a Trabant/Yugo joke. Some of the attenders got the point. You had to be there. Clive Cork related stories about ducks and a demolition derby; where does he get these stories?! Dave Sharp told of his Director's sedan crash. Jon Crull told of a loader mishap and Sharan Fosbinder explained about rescuing pigeons. Clive's duck tale won.

2:10 p.m. - Rap Session.

Doug Mattocks, Volusia County, asked about the pros & cons of using a single grade oil for all vehicles. Most members expressed a preference for using one oil for all vehicles. Discussion ensued.

Greg Schmidt, City of Melbourne, asked about members experience with conducting examinations for Commercial Driver's Licenses in-house and could one governmental entity perform examinations for another entity. It was expressed that it was possible. Discussion ensued.

Dexter Martin, Gainesville Regional Transit Systems, related information regarding a Federal DOT requirement for certification of all mechanics who perform brake repairs on for-hire (buses, etc.) vehicles. He has copies of requirements for anyone interested.

Clive Cork, City of Coral Gables, asked if anyone had information on the new air conditioning freon requirements. Discussion ensued.

Kurt Miller, Pinellas County, asked if anyone knew what a normal downtime percentage was on a national level and how downtime is defined. It was represented that 5% was accepted as normal. A discussion ensued on the definition of downtime.

2:55 p.m. - Jon Crull announced that the next meeting would be on September 10 + 11, 1992 at the Treasure Island Inn, Daytona Beach Shores. He announced that a tentative speaker would be Michael Corbett, Editor, CALIFORNIA FLEET NEWS. Jon also announced that plans for a tour of the Daytona Speedway were being worked on with Larry Baleski of the Daytona Speedway Authority. He also mentioned that Altec Industries and Bell Additives were hosting hospitality suites after the meeting adjourned for the evening.

3:00 p.m. - Break.

3:15 p.m. - Jon Crull announced that Custom Compactors had a demonstration unit of their oil filter crusher in the hotel parking lot. Jon then introduced Richard Quine of P.I.E.C.O., who gave a presentation on the history of underground storage tank regulations and what impact future regulations would have on fleet managers.

4:20 p.m. - Break.

4:25 p.m. - Jon Crull, F.A.G.F.A. President called the business meeting to order for regular members.

OLD BUSINESS

Vern Tucker, City of Ocala moved to accept the minutes of the September 1991 meeting. Elliot Covo, City of Miramar, seconded. Motion carried.

NEW BUSINESS

Sharan Fosbinder, F.A.G.F.A. Treasurer, gave the Treasurer's report for the periods of February 1991 through August 1991 and September 1991 through March 1992. Clive Cork moved to accept the Treasurer's report. Vern Tucker seconded. Motion carried.

Elliot Covo moved that the Association purchase a set of Kelly Walker's training manuals for the use of Association members. Copies could be made for use of the Association members only. Kelly explained that portions of his manuals were especially appropriate for inclusion in the Association's privatization RFP. Larry Mandelion, City of Margate, seconded. Motion carried.

Charles "Dusty" Miller, City of Jacksonville, moved that the Association review Kelly Walker's manuals with the intent of determining the feasibility of a custom seminar for the Association. Motion was tabled for further review.

Greg Schmidt moved that instead of the Association incurring the cost for duplication and distribution of the Kelly Walker manuals each member should pay Kelly Walker. Discussion ensued on various payment methods. Motion was tabled for further review.

John Warbington moved that the format of the Association Meeting Agenda should be modified to more accurately reflect the activities taking place. Discussion ensued on possible alternatives. Motion was tabled for further review.

Clive Cork moved to adjourn the meeting. Milton Reid seconded. Motion carried.

4:50 p.m. - Meeting adjourned.

Friday, May 1, 1992

8:55 a.m. - The General Membership meeting reconvened. Jon Crull asked the Association to recognize Past-President, Clive Cork for his hard work and dedication in serving as President for the last year.

9:05 a.m. - Association 2nd Vice President, Jim Aggeles introduced Kurt Miller, Pinellas County Fleet Management Director, who gave a presentation on "Being Competitive". Mr. Miller defined what competitiveness means and reinforced the need to set management goals and objectives. Mr. Miller concluded his presentation with a question and answer session in which the definition of 'down-time' was discussed.

10:15 a.m. - Break - 50/50 Raffle. Congratulations to Jim Goranson, Citrus County, and thanks for donating it back to the Association. Drawings were held for the Chicago Pneumatic Air Impact Gun door prize and the baseball caps.

Air Gun:	Clive Cork	
Baseball Caps:	Bob Minton	Ray Tuttle
	Bernhardt Schilling	William Masey
	Charles Whitehead	Joe Perry
	David Vanosdoll	Paul Turner
	Walter Piff	Al Cake
	Charles Miller	Kurt Miller

10:25 a.m. - Jon Crull introduced Fred Van Waldick, Coastal Detroit Diesel/Allison, who gave a presentation on the Allison "World Transmission". Mr. Van Waldick explained the modular design and electronic controls options.

11:10 a.m. - Jon Crull introduced Tripp Simms, Accu-Scan, who gave a presentation on "Bar-Coding". Mr. Simms explained the steps necessary for successful implementation of a bar-coding system.

11:45 a.m. - Rap Session.

Kelly Walker informed the Association of Vice President Quayle's recommendation to President Bush about advising municipal governments to consider selling capital assets (bridges, roads, buildings, etc.) to private organizations. He also advised the Association that a Privatization Council had recently convened and they had made more than 100 calls in Florida alone. Discussion ensued.

Clive Cork stressed the need for documentation of all service activities; good and bad. Don't just say "Replaced Battery"; detail all activities. Discussion ensued.

Doug Brock stressed the importance of recording and reporting utilization trends. He stated that if you could reduce vehicle count through better utilization, fleet costs would be reduced. Discussion ensued.

Dusty Miller stressed the need for vehicle information standards. He suggested that the Association form a committee to develop information standards such as down-time and productivity rates. Discussion ensued.

Luis Tamayo asked if anyone's job descriptions for mechanics includes a requirement for A.S.E certification. Attenders were divided 50/50 on those that do and those that don't. Luis also asked if members were using Mechanic I, II, III or generic ratings and whether tests were administered for new-hires or promotions. He also asked if flat-rate labor standards were being used for pay incentives. Discussion ensued.

Jon Crull read an article from "Governing" magazine about privatization being one tool; not the only tool.

Ted Swick related information about Commercial Drivers Licenses (CDL) mandatory physicals and drug testing for new drivers.

Paul Turner informed the Association that CDL 'Grand-Fathered' employees could pose a liability risk. He advised that all employees should be tested and inspected and not 'Grand-Fathered' in. Discussion ensued.

Richard Collins asked how many members paid for employee's CDL tests and licenses. Discussion ensued. Only a few paid for CDLs.

Luis Tamayo informed the Association that a Federal law (American Disabilities Act) requires an employer to make reasonable accommodations for disabled employees. This could cause the modification of governmental trucks and automobiles for disabled drivers. Discussion ensued.

Jon Crull announced that his new maintenance facility was open and offered tours to interested members. He also announced that Bell Additives would be sponsoring a High School Drag Racing Tournament Sunday, May 3, 1992 at 10:00 a.m. at the Orlando Speedway.

1:10 p.m. - Meeting adjourned.

1570

TREASURER'S REPORT

MARCH 1992
THRU
JULY/AUGUST 1992

BEGINNING BALANCE:		\$3,202.43
RECEIPTS:		
DUES	\$1,525.00	
REGISTRATION (60 @ \$15.00)	900.00	
DIVIDENDS	39.99	
CASH	200.00	
TOTAL RECEIPTS	<u>\$2,664.99</u>	\$2,664.99
TOTAL		<u>\$5,867.42</u>
EXPENDITURES:		
TREASURER ISLAND INN (APRIL MEETING)	\$1,033.82	
RETURN CK/FEE	40.00	
CHECKING FEE (MAR/APR/MAY/JUN/JUL)	37.50	
PRIVATIZATION BOOK (CHECKING ACCT)	701.96	<i>omit as recurring item</i>
PRIVATIZATION BOOK (CASH)	93.28	
PRINTING FAGFA BOOK/ MAILING REG. FORMS	300.00	
KELLY WALKER MANUALS	500.00	<i>—)) —</i>
WED HOSPITALITY SUITE (PROCEEDS 50/50 CASH)	40.00	
TOTAL EXPENDITURES	<u>\$2,746.56</u>	\$3,120.86
SAVINGS:	<u>2,000</u>	
DIVIDENDS	\$ 52.41	
	.91	
TOTAL	<u>53.32</u>	

Attendance List
 General Membership Meeting
 FLORIDA ASSOCIATION OF GOVERNMENTAL FLEET ADMINISTRATORS
 April 30th & May 1, 1992
 Orlando, Florida

REGION	MEMBER	REPRESENTING
2	James M. Aggeles	Pinellas County
1	Jim DeMay	City of Tallahassee
3	Doug Brock	Orange County
3	Dan Burek	Walt Disney World
1	Richard Collins	City of Daytona Beach
4	Clive Cork	City of Coral Gables
4	Elliot Covo	City of Miramar
1	Jon Crull	City of Ormond Beach
3	Sharan Fosbiner	Orange County
4	Ken Friedrichs	City of Pembroke Pines
1	William Harris	Volusia County
4	Jim Hinds	City of Margate
3	Paul Kunz	Orlando Utilities Committee
4	David Kyzar	Town of Palm Beach
1	Jim Goranson	Citrus County Board of Commissioners
1	Dexter Martin	Gainesville Reg. Transit System
1	William G. Massey	City of Gainesville
1	Douglas Mattocks	Volusia County
2	John Kurt Miller	Pinellas County
2	Walter Piff	Manatee County
2	Dan R. Pucher	Collier County
1	Milton Reid	City of Gainesville
2	Edward Rownd	Seminole Fire & Rescue
3	Jerry N. Rude	City of Delray Beach
3	Bernie Schilling	City of Ormond Beach
3	Gregory Schmidt	City of Melbourne
3	Michael R. Scott	Orlando Utilities Comm.
3	Ted Swick	City of Lakeland
1	Luis Tamayo	So. Fla. Water Management Dist.
2	Harold Towry	Pinellas County Sheriff's Office
1	Vernon Tucker	City of Ocala
4	Paul Turner	North Miami Beach
2	David Vanosdoll	Sarasota County
3	John Warbington	Orange County
4	Douglas Weichman	Palm Beach County
3	Harold Wood	Kennedy Space Center
-	Vaughn Blake	Myer's Tire Supply
-		Florida Municipal
1	Alan W. Fyfe	Ucon Services, Inc.
-	Jack Schardine	Coastal Detroit/Allison

FOR YOUR INFORMATION

TRAINING VIDEOS - Listed below are the training videos available for F.A.G.F.A. use. If you have any videos available to add to the listing, please contact Kurt Miller at (813) 588-8150. Kurt is also the one to contact if you wish to borrow a video for your organization.

1. Back Injury Prevention
2. "Back Fire" (HCA Largo Medical Center)
3. Health Factors in Welding
4. Dangers of Asbestos (Clayton Brake Video)
5. It Always Happens to the Other Guy (2 tapes)
6. Winning Moves in Maintenance
7. Shake Hands with Danger (Forklift Safety)
8. Everything to Lose (Heavy Equipment Safety)
9. Maintenance Person Safety
10. Chains, Slings, Hoists Safety
11. Loader Operation (Parts I & II)
12. Mower Safety
13. Dump Truck Operation (Parts I, II, & III)
14. Dump Truck Safety
15. Bobcat Boot Camp
16. Tractor Safety
17. Sanding System (Training for Auto Body Work)
18. Clark Forklift Safety
19. "Color of Danger" (Safety Guide for Forklift Operation)
20. M.S.D.S., Right to Know (Education & Training-Auto Service)
21. Automotive Tape - "What You Should Know About Air Brakes"
22. Vehicle Inspection Module
23. Two Speed Axle Operation
24. Tracks (Shows Need for Driver Awareness & Co. Liability)
25. Backhoe Safety
26. Grader Operating (Parts I, II, & III)
27. The Burial Ground (Hazardous Waste - Who's Responsible?)

BY-LAWS AVAILABLE - The Association By-Laws will be made available for all who attend the meeting or anyone who requests them from Jon Crull. (Either by phone or letter)

CERTIFICATES OF MEMBERSHIP - Will be available at the meeting for anyone who has not yet received one.

COMMITTEES - As in the past, we encourage your participation in the rap sessions. So, be prepared to help shift the group into high gear with informative topics from your committee.

IN DUE TIME - Your \$20.00 (members) \$30.00 (associate members) will be needed again to keep our organization strong and effective. Please continue to support F.A.G.F.A. as you have in the past. Mail your dues to Sharan Fosbinder or pay them at the meeting.

EARLY REGISTRATION begins Thursday morning, April 30th, 8:15. With your cooperation, this should alleviate any need to delay the start of the meeting. We appreciate your cooperation.

PROBLEM SOLVING FLOWCHART

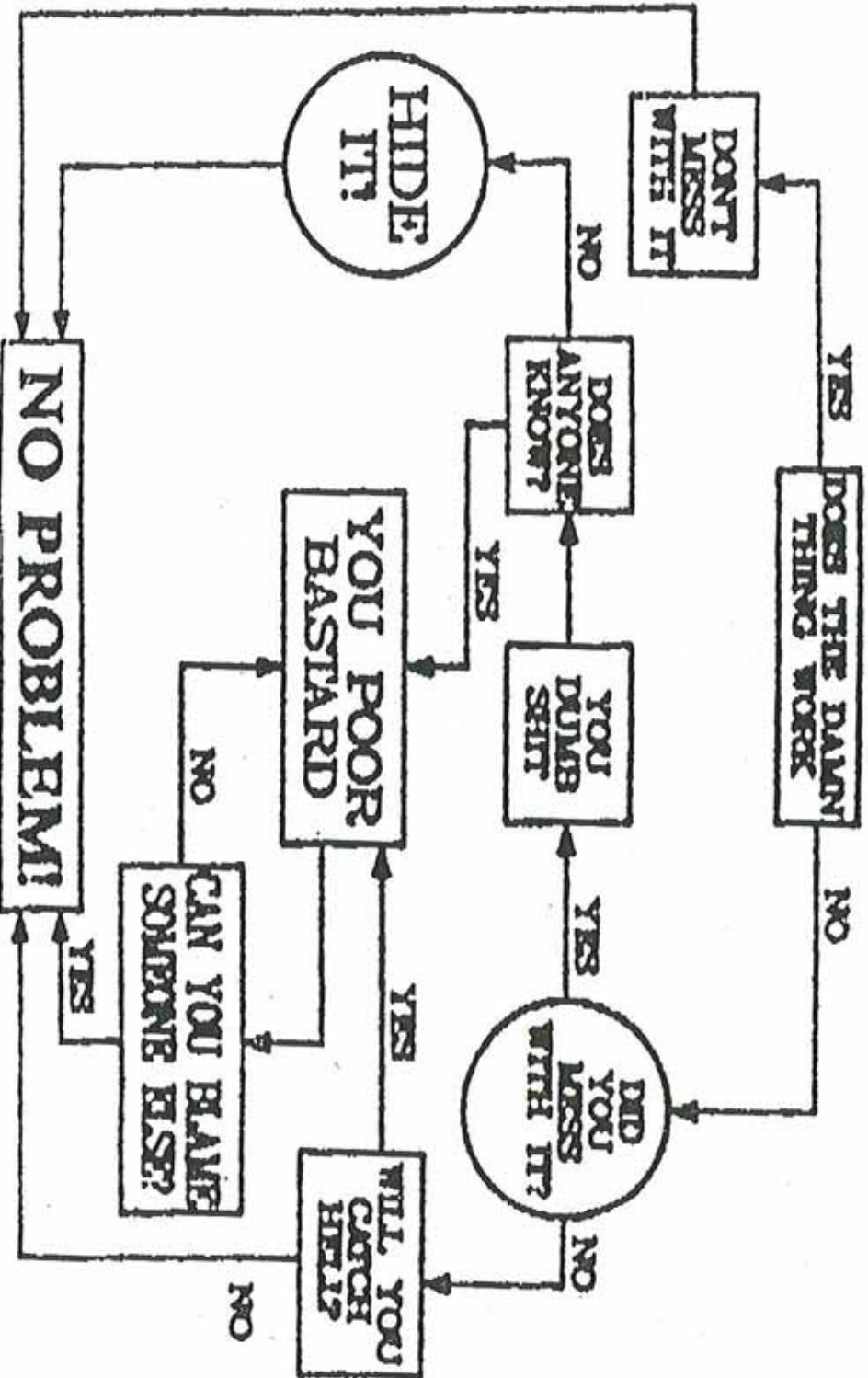

Florida Association of Governmental Fleet Administrators Fall 1992 General Membership Meeting

September 9 - 11 Agenda

WEDNESDAY, SEPTEMBER 9, 1992

- 5:00 - 9:00 pm Registration
6:00 - 7:00 pm Executive Committee Meeting
7:00 - 9:00 pm General Membership Meeting

THURSDAY, SEPTEMBER 10, 1992

- 8:15 - 9:00 Registration
9:00 - 9:15 Welcome, Introduction of Participants and Meeting Overview
9:15 - 10:15 Comparison of Fleet Organizations -- Michael Corbett, Editor/Publisher of California Fleet News, will compare various professional fleet organizations and other pertinent information.
10:15 - 10:30 Coffee Break
10:30 - 11:30 ~~Emissions Testing & Managing a Large Municipal Fleet -- Mark Glaibler of Metro Dade will provide us insight into the difficulties of managing a large municipal fleet (6,500+ vehicles) and compliance with Florida's Motor Vehicle Emissions Program.~~
Cancelled
Reg Tottle - NASA
11:30 - 1:00 Lunch at the Treasure Island Inn.
1:00 - 2:00 Pump It Up with Stan Whitlach of Bell Additives. Stan will be providing us with motivational skills.
2:00 - 2:15 Beverage Break
2:15 - 3:30 Rap Session and Fleet Funnies
3:30 - 3:45 Beverage Break
3:45 - 5:00 Business Meeting and Election of Officers.
-

FRIDAY, SEPTEMBER 11, 1992

8:30 - 9:00 Coffee and Registration

9:00 - 10:00 Benchmarking -- Robert E. (Chip) Taggart, David M. Griffith & Associates, talks about maintenance benchmarks we can all use for maintaining competitiveness.

10:00 - 10:15 Beverage Break

10:15 - 11:00 Safety & the Fleet Administrator -- Charles E. (Dusty) Miller, City of Jacksonville, explains the importance of safety in fleet administration.

11:00 - 12:00 Rap Session

12:00 - 1:00 Lunch

1:00 - 4:00 Tour of Daytona International Speedway -- Don't miss this exciting tour of the track which home to the famous Daytona 500 stock car race. (\$2.00 nominal charge.)

F.A.G.F.A. MEMBERSHIP LIST

James M. Ageles
Equipment Acquisition Specialist
Fleet Management Pinellas County
9685 Ulmerton Rd.
Largo, FL 34641
(813) 588-8175
F.A.G.F.A. 2nd Vice President
FLEET LINE EDITOR

James L. Beekman, Jr.
Supervisor Vehicle Maintenance
Osceola District Schools
2450 Old Dixie Highway
Kissimmee, FL 34744
(407) 847-2875

Gerald Beduch
Superintendent Equipment Maintenance
630 N.W. 2nd Street
Hallandale, FL 33009
(305) 457-1613

Paul Bishop
Operator Trainer
Pinellas County Fleet Management
9685 Ulmerton Rd.
Largo, FL 34641
(813) 588-8150

Tom Blanke
Fleet Equipment Admin.
Metro-Dade GSA Fleet Management
111 N.W. 1st Street
Suite 2530
Miami, FL 33128
(305) 375-5139

Lawrence S. Block
Maintenance Supervisor
Broward County Equipment Division
1600 Blout Rd.
Pompano Beach, FL 33069
(305) 745-8302

Doug Brock
Assistant Fleet Manager
Orange County
1431 Casa Rio Dr.
Orlando, FL 32825
(407) 273-5059

Dan Burek
Walt Disney World
Fleet Management
P.O. Box 10000
Lake Buena Vista, FL 32830
(407) 824-6102

Gary Carter
Fleet Maintenance Supervisor
1050 Malabar Road SW
Palm Bay, FL 32908
(407) 727-7100 Ext. 177

David Y. Chappell
Executive Director
Coastal Health Sys. Brevard, Inc.
P.O. Box 560386
Rockledge, FL 32956-0386
(407) 631-1446

Paul Cheeseborough
Fleet Management Administration
1250 Highland Street
Mount Dora, FL 32757
(904) 735-7151

Fred Chester
Garage Supervisor
City of Temple Terrace
6009 White Way Dr.
Temple Terrace, FL 33617
(813) 989-7170

Richard Collins
Equipment Manager
City of Daytona Beach
P.O. Box 2451
Daytona Beach, FL 32115
(904) 258-3193

F.A.G.F.A. MEMBERSHIP LIST

Gregory Cook
Regional Transit System Director
City of Gainesville
100 S.E. 10th Avenue
Gainesville, FL 32601
(904) 374-2609

J. Dale Cook
Vehicle Maintenance Supervisor
Marion County
3240 E. Maricamp Rd.
Ocala, FL 32671
(904) 694-2515

Clive Cork
Automotive Director
City of Coral Gables
340 San Lorenzo Avenue
Coral Gables, FL 33146
(305) 460-5144

Elliot Covo
City of Miramar
7000 Miramar Parkway
Miramar, FL 33023
(305) 431-3795

David Craft
Shop Superintendent
City of Altamonte Springs
225 Newbury Avenue
Altamonte Springs, FL 32701

Jon Crull
Director of Fleet Operations
City of Ormond Beach
P.O. Box 277
Ormond Beach, FL 32075
(904) 676-3265/6
F.A.G.F.A. PRESIDENT

James E. Culp
Garage Supervisor
City of Lake Worth
7 North Dixie
Lake Worth, FL 33460
(407) 586-1722

B.H. "Bud" Damron
Fleet Service Manager
Marion County Sheriff's Department
P.O. Box 1987
Ocala, FL 32678
(904) 622-3331

Benjamin L. Delaney
Fleet Manager
Largo Municipality Fleet Center
P.O. Box 296
Largo, FL 34649-0296
(813) 587-6718

David A. DellaPenta
Electric Shop Supervisor
Broward County Equipment Management
12900 S.W. 13th Manor
Davie, FL 33325
(305) 473-5786

James H. DeMay
Fleet Superintendent
City of Tallahassee Fleet Management
400 Dupree Street
Tallahassee, FL 32304
(904) 574-5220

Robert Eichorst
Acting Director of Public Works
P.O. Box 310
City of Boynton Beach
Boynton Beach, FL 33435
(305) 734-8111 Ext. 424

Thomas Elliott
Shop Foreman
City of Winter Park
401 Park Avenue South
Winter Park, FL 32789
(407) 623-3293

Donald Emrick, Jr.
Fleet Supervisor
750 Milwaukee Avenue
Dunedin, FL 34698
(813) 738-1886

Richard Evans
Fleet Acquisitions Supervisor
City of Tampa
1508 Clark Avenue
Tampa, FL 33607
(813) 878-1004
F.A.G.F.A. SECRETARY

Carel W. Fisher
Assistant Director of Public Works
City of Boynton Beach
P.O. Box 310
Boynton Beach, FL 33435
(407) 738-7421

F.A.G.F.A. MEMBERSHIP LIST

Sharan Fosbinder
Orange County
2450 33rd St.
Orlando, FL 32809
(407) 836-7800
F.A.G.F.A. TREASURER

Ken Friedrichs
Superintendent of Mechanic Services
City of Pembroke Pines
13975 Pembroke Road
Pembroke Pines, FL 33207
(305) 437-1120

Donald A. Gardner
Automotive Service Manager
City of Fort Lauderdale
P.O. Box 14250
Ft. Lauderdale, FL 33302
(305) 761-5046

Jimmy J. Gilliard
Public Works Director
City of Rockledge
P.O. Box 560488
Rockledge, FL 32956-0488
(407) 636-1951

Gary Giragosian
Service Manager
City of Boca Raton
2500 N.W. 1st Avenue
Boca Raton, FL 33431
(305) 393-7889

Mark Glaiber
Director Metro-Dade Fleet Management
111 N.W. 1st Street
Miami, FL 33128
(305) 375-2284

Paul Gray
Fleet Operations Trainer
City of Clearwater
P.O. Box 4748
Clearwater, FL 34618-4748
(813) 462-6891

George Hales
Fleet Maintenance Supervisor
901 Ponce DeLeon Blvd.
Belleair, FL 34616
(813) 581-3841

William Harris
Fleet Manager
Volusia County
1270 Indian Lake Rd.
Daytona Beach, FL 32124
(904) 254-1595

Ivey J. Hill
Assistant Fleet Supervisor
City of Tallahassee
400 Dupree St.
Tallahassee, FL 32304
(904) 574-5226

Jim Hinds
Fleet Administrator
City of Margate
5790 Margate Blvd.
Margate, FL 33063
(305) 972-8126

Donald Hulse
Fleet Maintenance Manager
Orange County Sheriff's Office
4549 L. B. McLeod Rd.
Orlando, FL 32811
(407) 423-7934

C.O. Johns
1st Sergeant
Manatee County Sheriff's Office
515 11th St. W.
Bradenton, FL 34205
(813) 756-4752

Kurt B. Jokela
Assistant Fleet Manager
Collier County Fleet Management
3301 Tamiami Trail
Naples, FL 33962
(813) 793-5655

Joseph M. Keener
Supervisor, City Garage
City of Cocoa
301 Shearer Blvd.
Cocoa, FL 32926
(407) 639-7675

James Kraner
Fleet Maintenance Supervisor
City of Longwood
180 E. Warren Avenue
Longwood, FL 32750
(407) 831-6175

F.A.G.F.A. MEMBERSHIP LIST
ASSOCIATE MEMBERSHIP ROSTER
MARCH 17, 1992

Gregg Jacobs
Director of Marketing
190 W. Napa St.
Sonoma, CA 95476
(707) 935-6191
Representing: Computer Software

Gene Kesser
Vice President Marketing
1180 N.W. 163rd St.
Miami, FL 33169
(305) 620-7630
Representing: Carburetion
Labs International

Paul Lauria
Manager Ernst & Young
1200 19th St. N.W.
Washington, D.C. 20036
(202) 862-9318
Rep.: National Transportation
Consulting Group

Robert D. Long
Division Manager
Professional Service Industries
2825 Breckinridge Blvd.
Duluth, GA 30136
(404) 279-1370
Representing: Technology Appl.

Jack Mears, Executive Director
Equipment Maintenance Council
113 Highland Lake Rd.
Lewisville, TX 75067
(214) 436-9257

M.C. Morgan
Sun and Sea Sales
111 75th Street
Holmes Beach, FL 34217
(813) 778-1364
Representing: Petrolon/Scientia

Patrick D. Murphy
Project Director
P.O. Box 885
Monterey Park, CA 91754
(213) 267-2337
Representing: Holmes/Narver Services

James McIntosh
District Sales Manager
P.O. Box 951987
Lake Mary, FL 32795-1987
Representing: Cronatron
Welding Systems

Pride of Florida 3950
3950 Tiger Bay Rd.
Daytona Beach, FL 32014
(904) 254-3916

Regina Raitano
President
Loading Dock/Door Spec. Inc.
P.O. Box 82966
Tampa, FL 33682-2966
Representing: Sauk Valley Equip.

Ronald T. Riley
Regional Sales Manager
7401 S.W. 133rd Avenue
Miami, FL 33183
(305) 387-1208
Representing: Sefac Litt & Equip. Corp.

Jack Schardine
Customer Prts/Service Rep.
1500 Dolgner Place
Sanford, FL 32711
(407) 323-3510
Rep: Coastal Detroit/Allison

David T. Scherr
Eastern Regional Manager
71 Grand Avenue
Palisades Park, NJ 07650
(201) 941-4150
Representing: Cayton Industries

Leo W. Stutsman
President
617 Lithia Rd.
Brandon, FL 33511
(813) 689-7855
Representing: Perfect Filtration



THE FLORIDA ASSOCIATION OF
GOVERNMENTAL FLEET ADMINISTRATORS, INC.



MEMBERSHIP APPLICATION/RENEWAL

TO THE TREASURER AND SECRETARY:

DATE: _____

Name: _____

Title: _____

Mailing Address: _____

Zip Code: _____

Area Code and Phone Number: _____ Fax Number: _____

Representing: _____

Business Address: _____

Zip Code: _____

Municipality _____ County _____ State _____ Federal _____ Other _____

Number of Years in current Position: _____

Number of Years in Governmental Fleet Operations: _____

Total Number of Years in Fleet Operations: _____

Type of Application: Renewal _____ Member _____ Associate Member _____

Signature of Applicant

Date

Approved: _____

Treasurer

Date

ANNUAL MEMBERSHIP DUES: Regular \$20.00 Associate: \$30.00

Enclose check or money order payable to the FLORIDA ASSOCIATION OF
GOVERNMENTAL FLEET ADMINISTRATORS and mail to:

Sharan Fosbinder, F.A.G.F.A. Treasurer
Orange County
2450 33rd St.
Orlando, FL 32809